

**DRY RISER INLETS BOX**

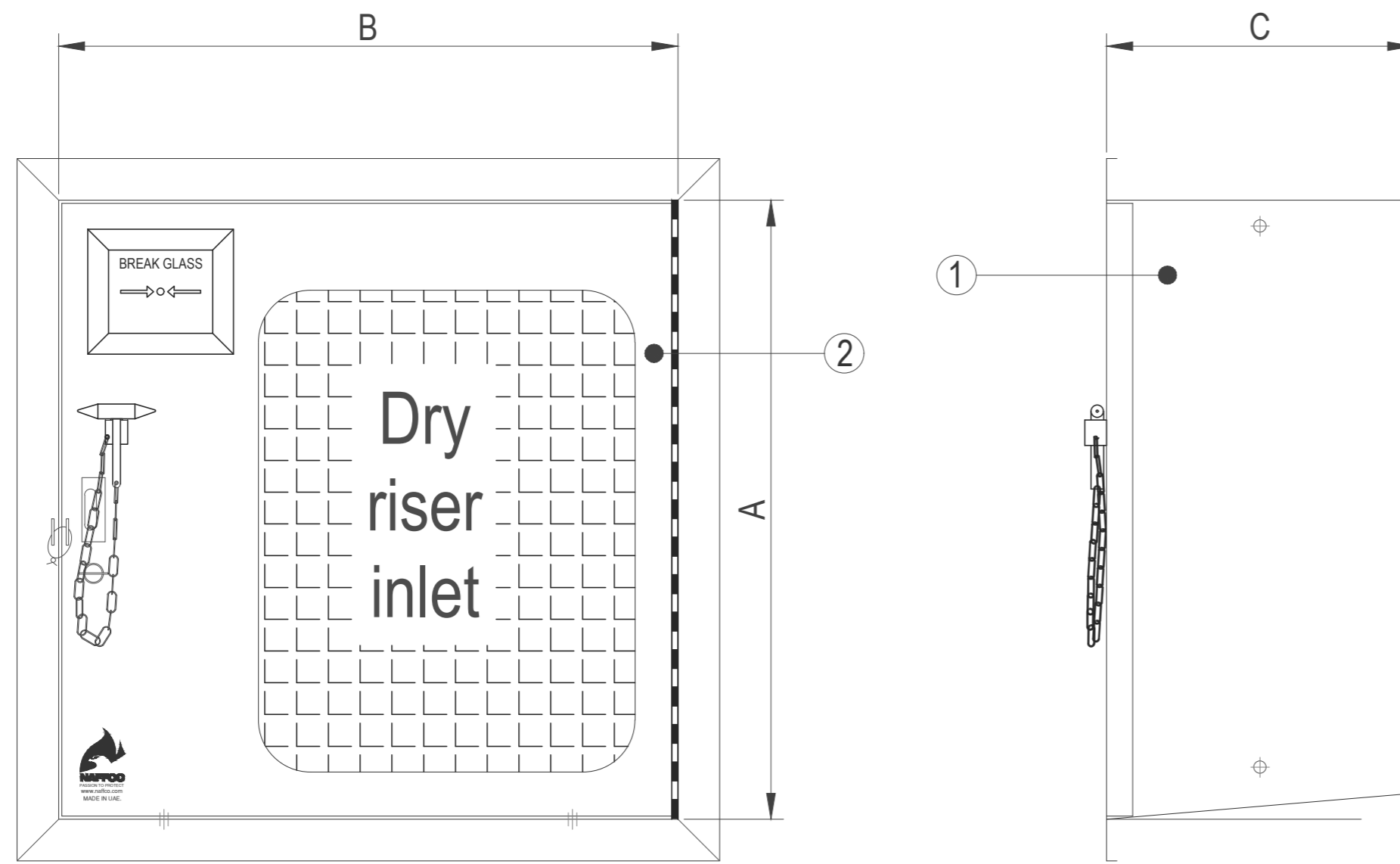

**ELEVATION**

**SECTIONAL VIEW**



**NOTES :-**

1. ALL DIMENSIONS ARE IN mm. UNLESS OTHERWISE SPECIFIED

**BILL OF MATERIALS**

ITEM NO.	DESCRIPTION	MATERIAL	QTY.
1.	CABINET BODY	ELECTRO GALVANISED STEEL SHEET	1
2.	DOOR & FRAME	ELECTRO GALVANISED STEEL SHEET	1

**SPECIFICATIONS**

MODEL	DESCRIPTION	DIMENSION		
		A	B	C
NF-2WDRIC-SM	4" x 2 WAY BOX FOR DRY RISER INLETS,SURFACE MOUNTED,HORIZONTAL	595	395	295
NF-4WDRIC-SM	6" x 4 WAY BOX FOR DRY RISER INLETS,SURFACE MOUNTED,HORIZONTAL	595	595	295
NF-2WDRIC-SMA	4" x 2 WAY BOX FOR DRY RISER INLETS,SURFACE MOUNTED,VERTICAL	395	595	295
NF-2WDRIC-RT	4" x 2 WAY BOX FOR DRY RISER INLETS,RECESSED TYPE	595	395	295
NF-4WDRIC-RT	6" x 4 WAY BOX FOR DRY RISER INLETS,RECESSED TYPE	595	595	295
NF-2WDRIC-RTA	4" x 2 WAY BOX FOR DRY RISER INLETS,RECESSED TYPE	395	595	295